

# GTCL

## Bran cutting machine

Using the GCTL bran shredder it is possible to reduce in one single process the granulometry of bran from 700-800 to 250 microns, producing a homogeneous wholemeal flour suitable for the requirements of the food processing industry. Golfetto Sangati, unique in the world, has been producing this type of shredder for decades, also using it for other applications. The current market demand has led Golfetto Sangati to reengineer the GCTL by equipping it with a 98-bladed steel shaft (tempered steel blades) with a maximum rotation speed of 3500 rpm. The shaft is inserted inside a casing that rotates in the opposite direction, guaranteeing the highest grinding performance and facilitating the cleaning effect ensured by a rotating brush made of nylon threads and a pneumatic brush.

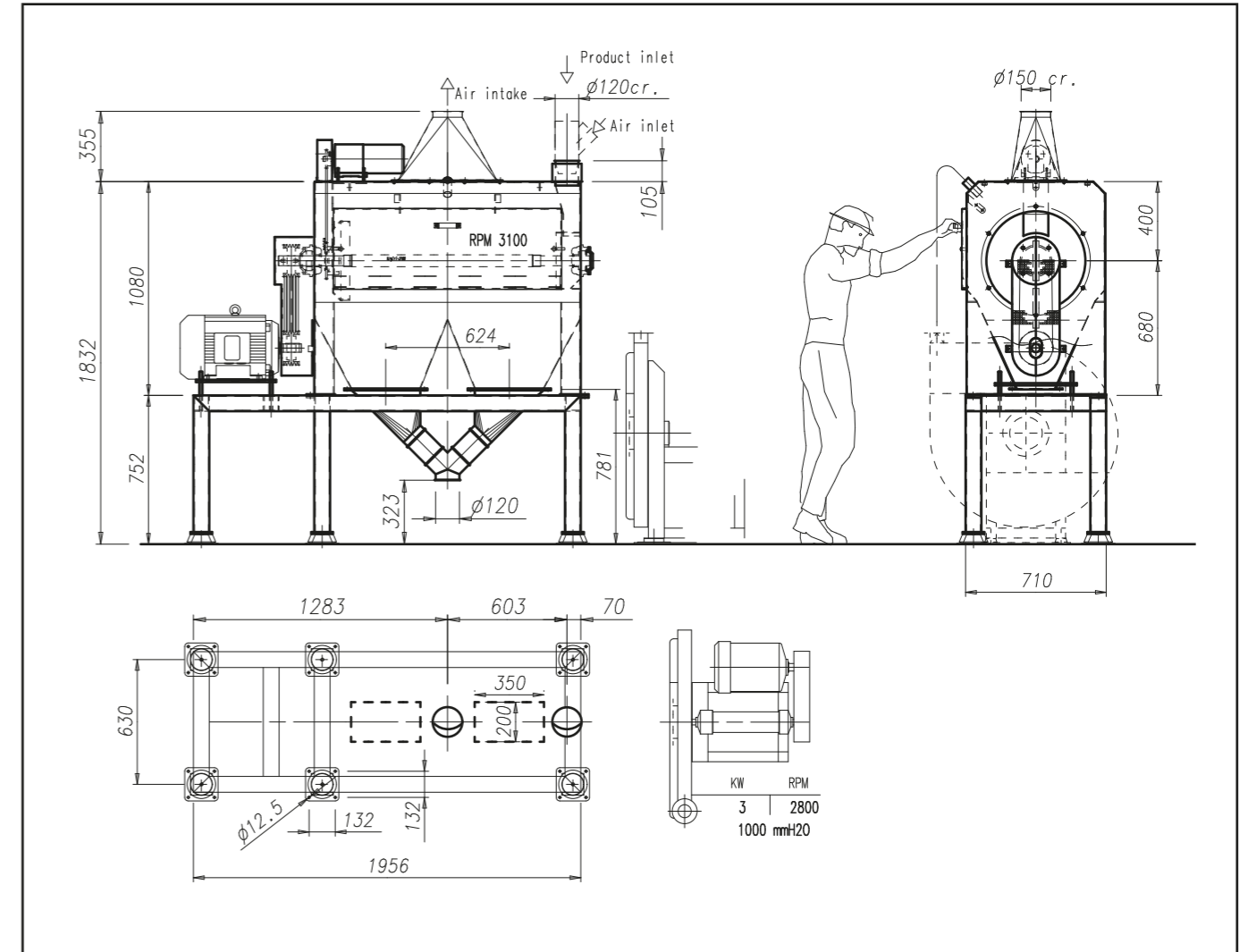

Capacity t/h	Cover $\phi \times L$	Air intake		Rotor motor power kW	Cover motor power kW	Weight Kg
		$m^3/1'$	mmH2O			
1	410x1000	15	70	18.5	0.37	1300

Units = mm